

DOUBLE WOODEN CABANA ASSEMBLY INSTRUCTIONS

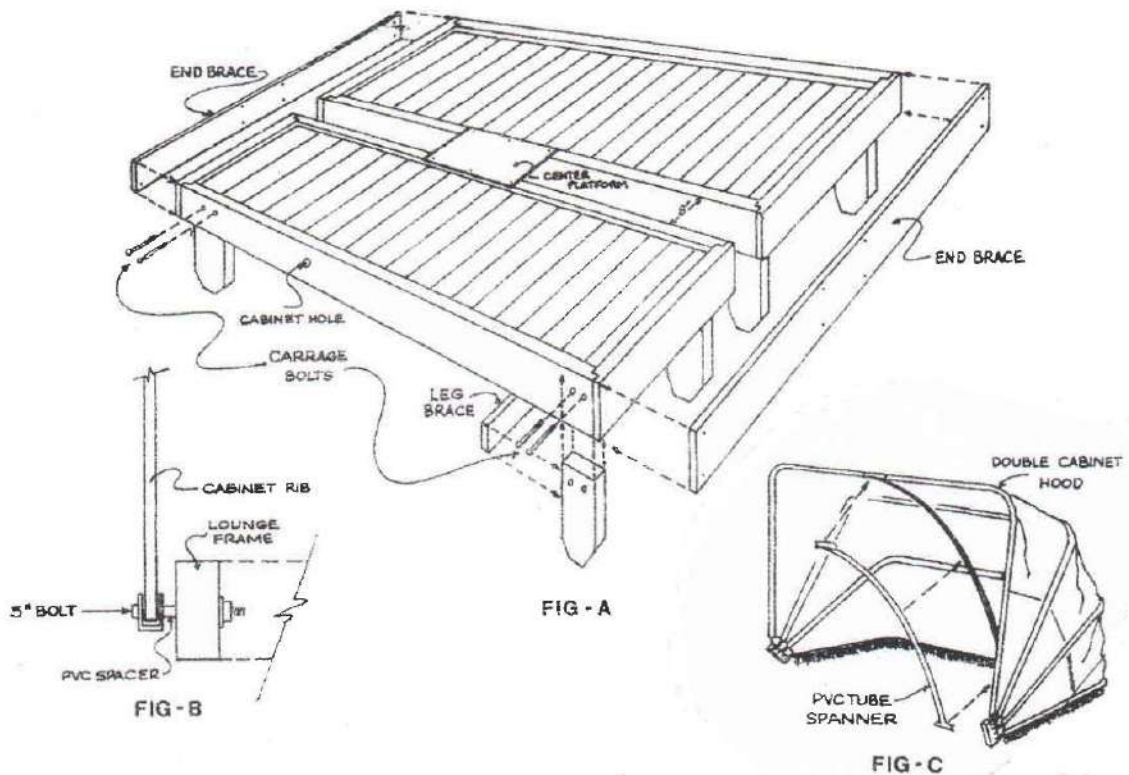

DOUBLE WOODEN LOUNGE ASSEMBLY

1. PLACE TWO SINGLE LOUNGES APPROXIMATELY 8" APART.
 2. FASTEN END BRACES (SEE FIGURE A) WITH 1 1/2" WOOD SCREWS HOLES PREDRILLED IN BRACES.
 3. FASTEN CENTER PLATFORM TO LOUNGE (SEE FIGURE A) WITH 1" WOOD SCREWS.
- NOTE: TO START SCREWS TAP WITH HAMMER AND THEN DRIVE WITH SCREWDRIVER.

TO CONNECT CABANA HOOD (HARDWARE INCLUDED)

1. BOLT HOOD TO DOUBLE LOUNGE (SEE FIGURE A&B) WITH 5" BOLTS. BE SURE TO INCLUDE SPACER.
2. PVC SPANNER ROD IS USED TO HOLD HOOD OPEN (SEE FIGURE C). HOLD HOOD OPEN AND BEND SPANNER BAR INWARD BETWEEN TOP AND BOTTOM.